



# K-D Assembly Instructions - 2 & 4 Panel

## SLIDING PATIO DOOR

**TOOLS REQUIRED:** Safety Glasses, Rubber Mallet, Tape Measure, Level, Screw Driver, Drill, Phillips Head Drill Bit, 7/64" Drill Bit, Silicone Gun, Silicone, 1-1/4" Brad Nails and Brad Nailer, Stapler w/ 3/8" Staples.

### Supplied Fasteners

#6 X 2-1/2" Phillips Flat Head  
Frame: Qty 18 (2-Panel) / 20 (4-Panel)

#6 X 1-3/4" Phillips Flat Head  
Sill Stop Into Side Jamb: Qty 2  
Clad Frame Corner: Qty 2

#6 X 1" Phillips Flat Head  
Head Stop: Qty 8 (2-Panel) / 20 (4-Panel)

#6 X 5/8" Phillips Pan Head  
Endcap: Qty 2  
T-Rail: Qty 16 (2-Panel) / 32 (4-Panel)

#7 X 1/2" Phillips Flat Head  
Stationary Panel Filler Block To Sill:  
Qty 2 (2-Panel) / 4 (4-Panel)

#7 X 3/4" Phillips Pan Head  
Stile Cover Bracket: Qty 10  
Bumper Clip: Qty 4

#8 X 3" Phillips Pan Head  
T-Rail Install: Qty 16  
(8 Stainless, 8 Black)  
Head PVC Brickmould: Qty 2

#8 X 3/4" Phillips Flat Head Head  
Aluminum Astragal (4-Panel Only): Qty 10

### FRAME ASSEMBLY

1. Apply 1/16" silicon bead onto sill dado at both ends (Fig.1). **NOTE:** Frame needs to be assembled within 15 minutes of this silicon detail.

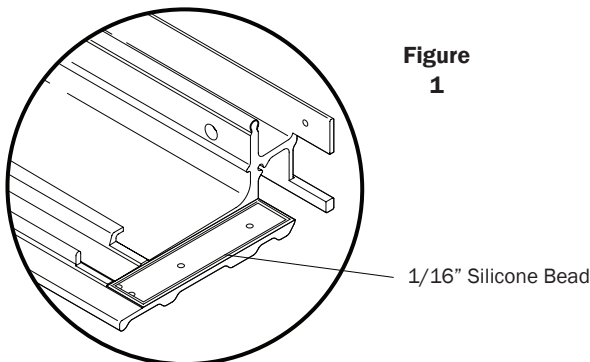


Figure 1

2. Lay side jamb assemblies, head jamb assembly, and sill on a flat level surface, exterior side down.
3. Screw the head and side jamb corners together using (4) #6 x 2-1/2" Flat Head screws, pre-drilling with 3/32" bit into wood before fastening with screws (Fig. 2). For clad units, apply (1) #6 x 1-3/4" Flat Head screw through head clad into side clad screw boss (Fig. 2). **NOTE:** Make sure screws line-up with screw bosses when assembling frame corners.

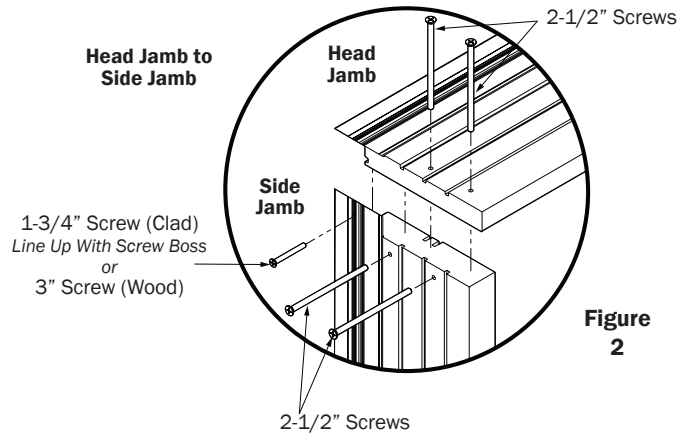


Figure 2

4. Clamp and screw sill corners together with (1) #6 x 2-1/2" Flat Head screw horizontally from side jamb into sill screw boss through pre-drilled holes, then (1) #6 x 1-3/4" Flat Head screw vertically into each side of frame cladding and note that the hole closest to the edge is for wood units only. Finally run (2) #6 x 2-1/2" Flat Head screws vertically from bottom of sill, up into side jamb (Fig. 3).

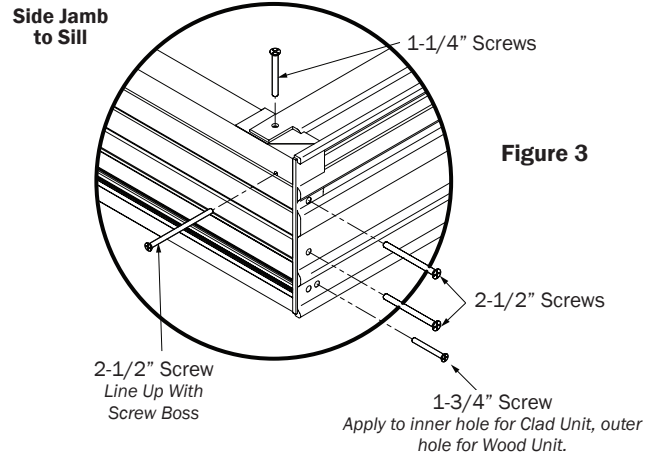


Figure 3

### STATIONARY PANEL PREP

5. Attach the clad cover brackets with the provided #7 x 3/4" Flat Head screws (Fig. 4). Space brackets evenly.

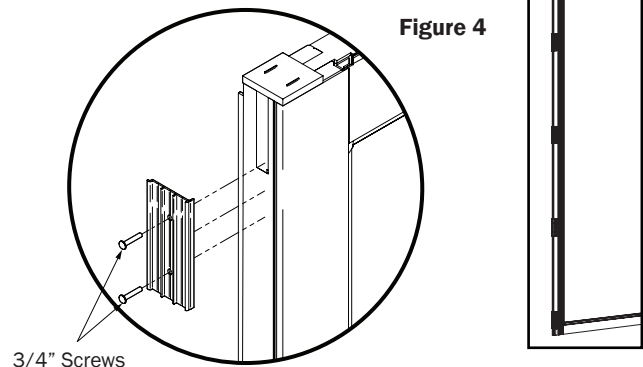


Figure 4

## STATIONARY PANEL INSTALLATION

- Before rotating panel into position, place a 1/4" horizontal bead of silicone along interior of screen track where stationary panel will be placed (Fig. 5).

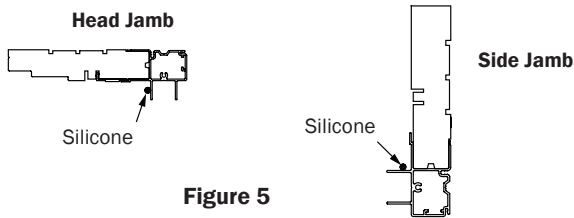


Figure 5

- Place a 1/4" vertical bead of silicone along interior of screen track where stationary panel will be placed, as well as into Kerfs at bottom of side jamb.
- From the interior, lift the stationary panel and tilt the top of panel to interior of frame. Place the bottom of the panel with the sill lug onto sill and tilt the panel outward until vertical. Slide the panel tight to the side jamb (Fig. 6).

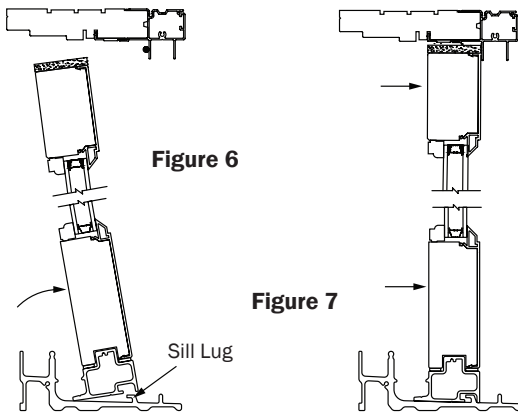


Figure 6

Figure 7

- Slide Stationary panel forward so entire panel is tight against sill lug (Fig. 7).
- Pre-Drill 3 holes into the sidejamb, one towards the top, one in the middle and one towards the bottom. Starting on one side and from the top, work down the frame to fasten the provided #6 x 2-1/2" Pan Head screws. The top screw will go through the headjamb and into the stationary panel stile at the interlock. Repeat on other side (OXXO only).

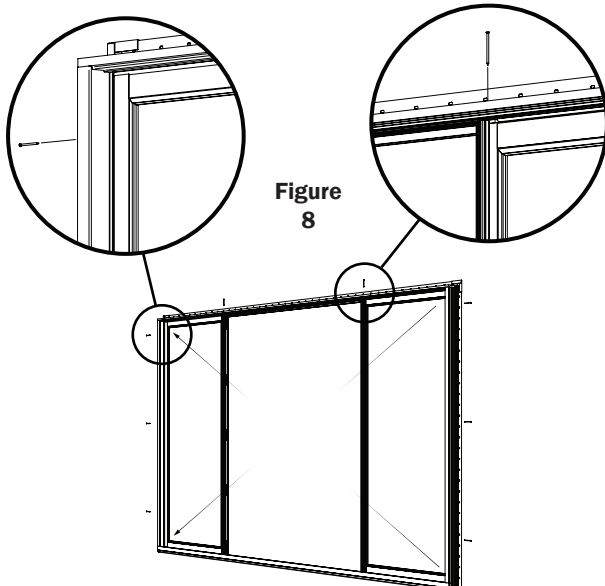


Figure 8

- Pre-drill 2 holes 2" from end of stationary filler O.C. using a 7/64" drill bit to a maximum depth of 1/4" and line up bit with screw hole scribe (Fig. 9). **DO NOT PENETRATE THROUGH SILL.**

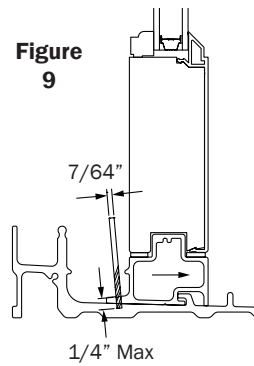


Figure 9

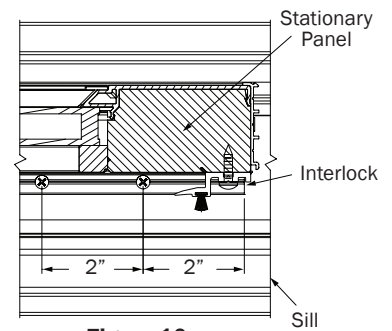


Figure 10

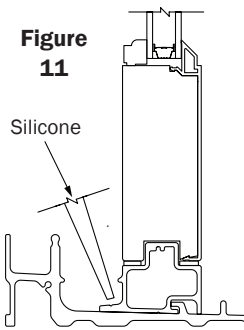


Figure 11

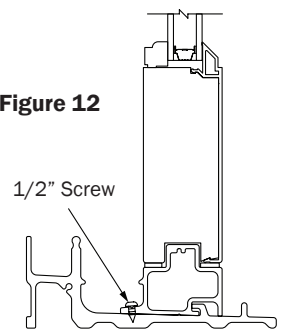


Figure 12

- Place silicone into pre-drilled holes before screw placement (Fig. 11) and attach two (2) #7 x 1/2" Flat Head Screws through sill lug and into sill (Fig. 12).
- Confirm that frame is square by measuring diagonally from corner to corner. Measurement must be within 1/8".

## INTERLOCK AND SILL COVER INSTALLATION

- Install the weather strip into the Interlock from the top and slide weather strip down to bottom of interlock (Fig. 13).
- Add a strip of silicone at top corner of stationary panel (Fig. 13).
- Install the aluminum parting stop into the headjamb. The center of the parting stop should be equal distance from each end of the frame. Attach 3/8" staples approximately 6" to 8" apart (Fig. 13 & 14).

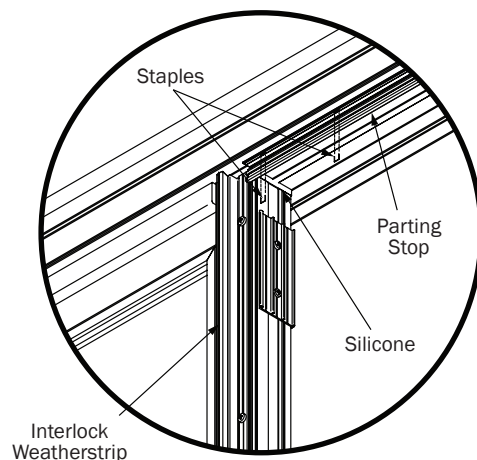
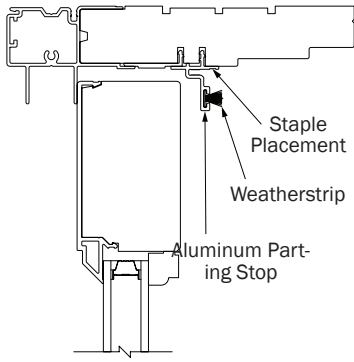
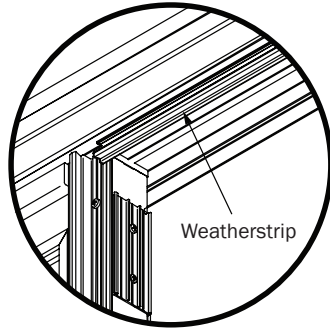


Figure 13



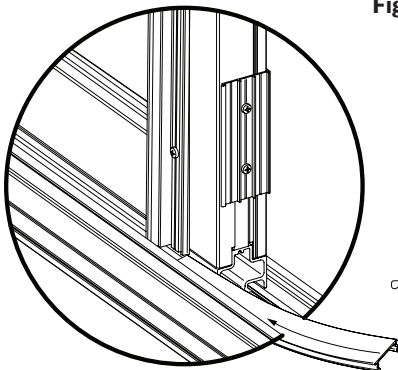
**Figure 14**

17. Once parting stop is in place, slide parting stop weatherstrip into parting stop T-slot (Fig. 15).

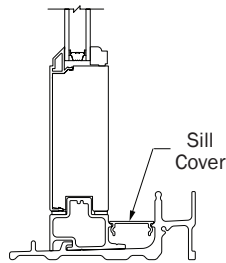


**Figure 15**

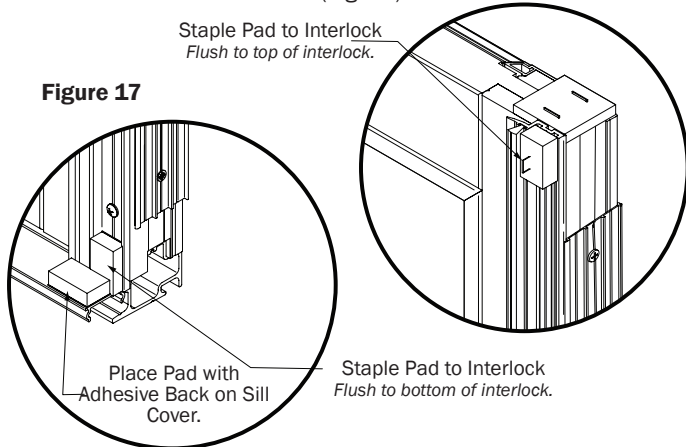
18. Slide sill cover into area between sill and sill block. Sill cover should then butt up against the side jamb (Fig. 16).



**Figure 16**

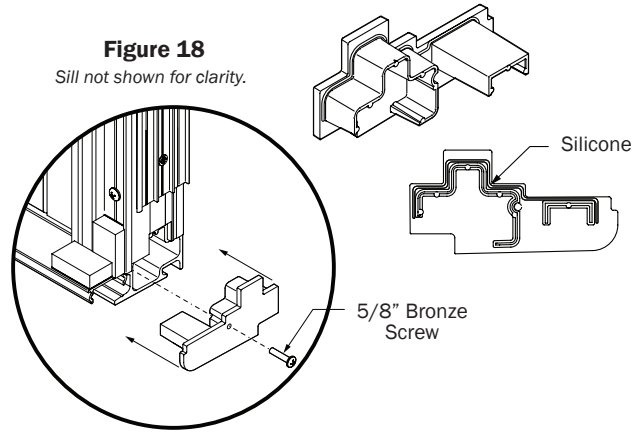


19. Attach dust pads after stationary panel is installed to frame and sill cover is attached to sill (Fig. 17).



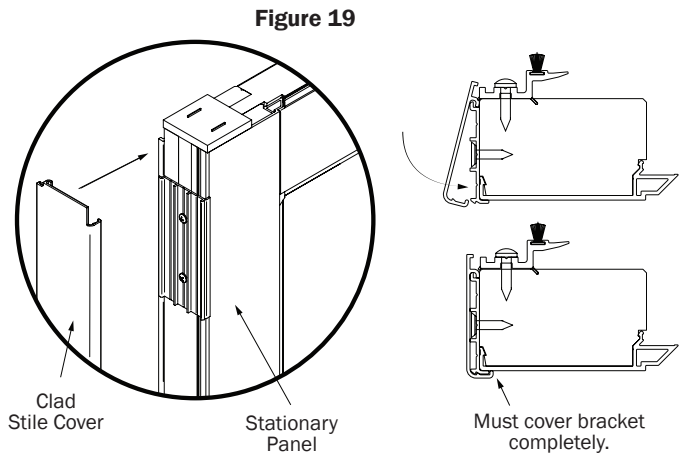
**Figure 17**

20. Install panel cap at base of stationary panel(s) by first applying 1/16" bead of silicone, as shown, to the cap and fastening into place with the provided #6 x 5/8" Pan Head screw (Fig. 18).



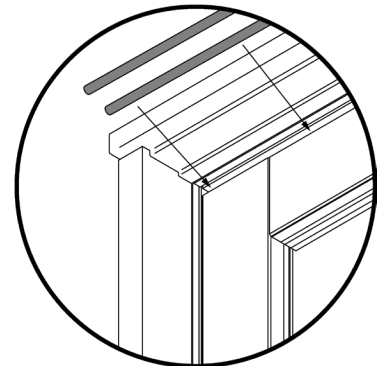
**Figure 18**

21. With the sill cover inserted and end cap installed on stationary filler, the clad stile cover needs to be applied to the end of the stationary panel. Hook clad stile cover onto interior side of cover bracket, rotate exterior stile face and snap into exterior side of bracket. Be sure stile cover is covering up bracket to exterior, no mill finish bracket exposure allowed. Tap down cover with rubber mallet if needed (Fig. 19).



**Figure 19**

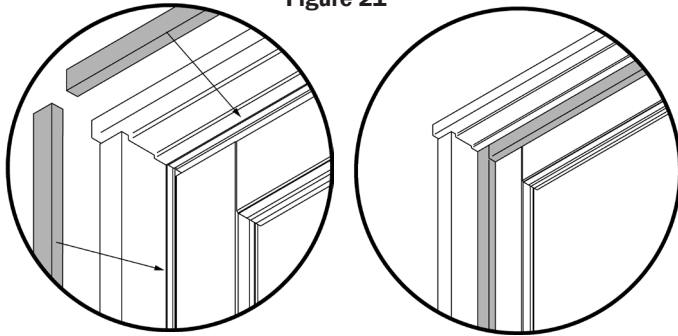
22. Place (2) 3/8" Diameter backer rods into cavity above the stationary panel. Backer rods should be as long as the cavity. Repeat for opposite side if door is an OXXO.



**Figure 20**

23. Attach the interior wood parting stops using 1-1/4" brad nails, spacing them 8" to 12" apart. Repeat for opposite side if door is an OXXO.

Figure 21



## OPERABLE PANEL INSTALLATION

24. To install the operable panel(s), the head stop and T-Rails, which are applied at the factory, will need to be removed first.

25. Remove the head stop by backing out the 1" Flat Head Screws and put aside (Fig. 22). These will be re-installed.

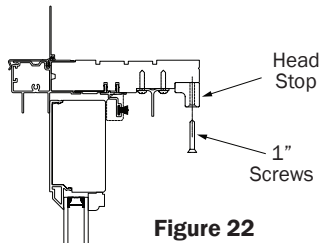


Figure 22

26. Remove T-Rails at the frame head by backing out the 5/8" screws and put aside (Fig. 23). These will be re-installed later.

27. Starting with one of the operable panels, place the corresponding side's T-Rail into the U-Guide at top of panel (Fig. 24).

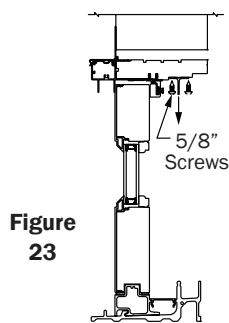


Figure 23

28. Lift the bottom of the panel with the rollers onto the roller track and tilt upright into place (Fig. 24).

29. Reattach the T-Rail to the head by replacing the #6 x 5/8" screws that you set aside. Hold onto active panel until t-rail is fastened. **Note:** The innermost holes (8) will require the 3" screws, step 30.

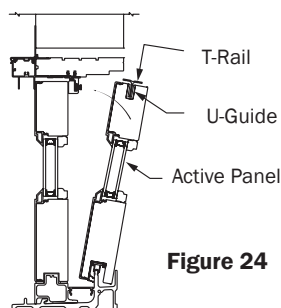


Figure 24

Repeat Steps 27-29 for the other operable panel (If door is an OXXO).

30. Slide the operable panels left and right to reveal the t-rail and the eight (8) innermost holes. Apply the #8 x 3" pan head screws (match the screw color to the t-rail color) into these holes, securing the door frame into the rough opening wood header (Figures 25-26). **Note:** Be sure to use shims between the door frame and header to prevent bowing the head jamb when the longer screws are applied.

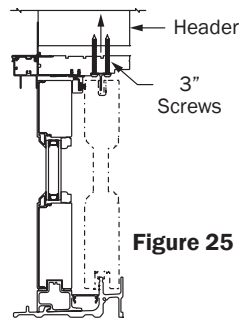


Figure 25

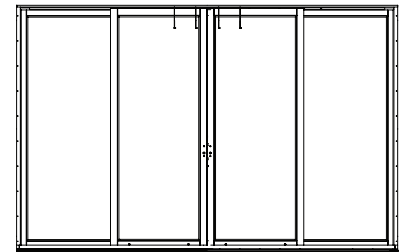


Figure 26

31. With the operable panels in place, reattach the head stop by replacing the 1" Flat Head screws that you removed in step 25 (Fig. 27).

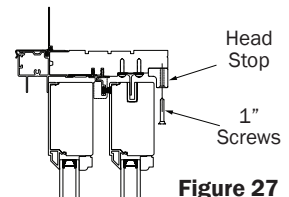


Figure 27

## PANEL ADJUSTMENT

32. To adjust the panels, the rollers can be accessed using the holes on the face of the bottom rails. Each roller can be adjusted separately using a phillips head screwdriver. Turning clockwise raises the panel and counter clockwise lowers the panel. Adjust until panel glides smoothly on the track and panel is plumb and level with the head. Top of panel should be approximately 1/4" from the head (Fig. 27).

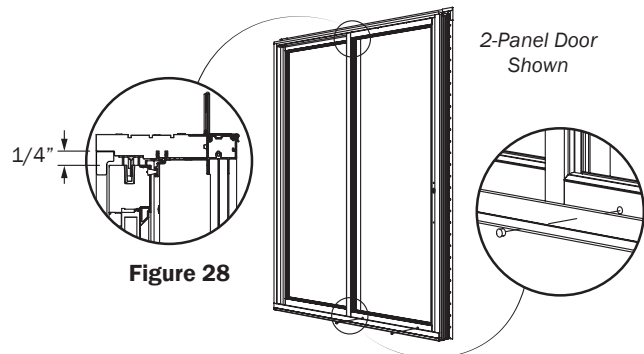


Figure 28

33. Install the provided plastic roller adjustment hole plugs when adjustment is complete.

## HARDWARE INSTALLATION

34. Attach the handle set and dummy handle set to the operable panel(s) following the provided manufacturer's instructions.

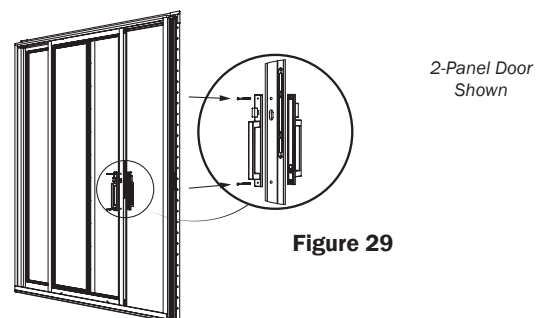


Figure 29

35. If a 2-panel door, to locate the keeper position on the jamb, place black locator within the latch (Fig. 30) and close the active panel strong enough to dimple the side jamb (Fig. 31).

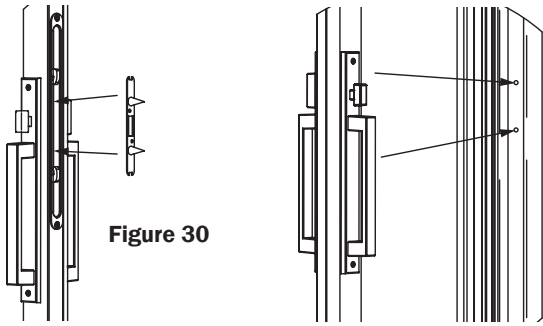


Figure 30

Figure 31

If an OXXO door, to locate the keeper position on the stile on the panel with the dummy handle, place black locator within the latch (Fig. 33) and close the active panel strong enough to dimple the other panel (Fig. 34).

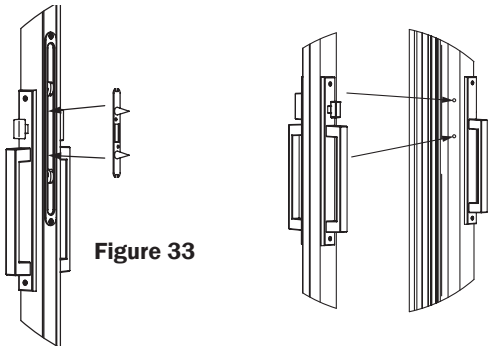


Figure 33

Figure 34

36. Using the dimples as a guide, install the keeper using the (4) #8 x 1-1/4" pan head screws. Adjust the keeper up or down until the latch engages properly, Fig. 35.

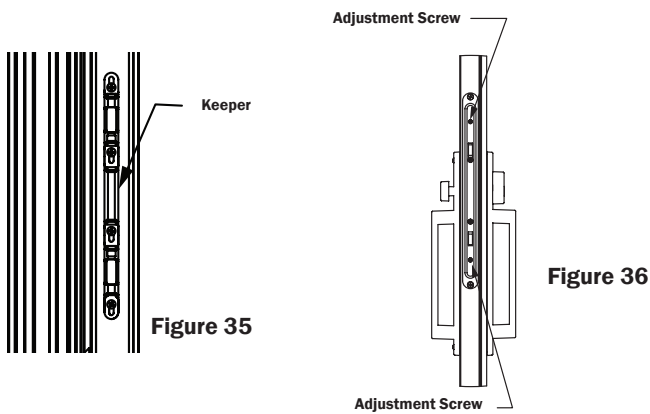


Figure 35

Figure 36

37. The screws in the lock can be adjusted (Figure 8) to make the door lock tighter or looser. Each hook adjusts individually.

38. Attach one of the supplied bumpers to the bumper clip located on the head jamb on the stationary panel side of the door. Apply by pressing the bumper up into the installed clip. Place the other bumper over the roller track on the sill (Fig. 37). Repeat on opposite side if door is an OXXO.

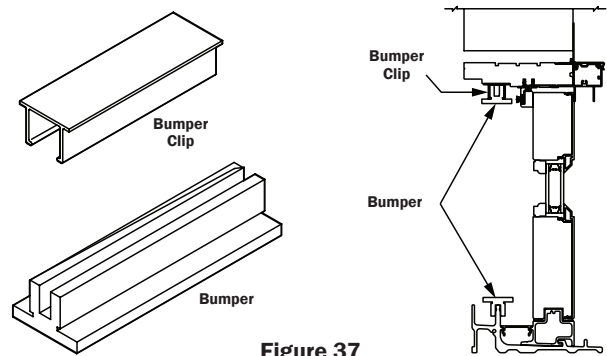


Figure 37

If door is a 2-panel, place supplied gasket on the sill against the side jamb over the operable panel track (Fig. 38). Gasket should sit underneath side jamb bulb weather-strip.

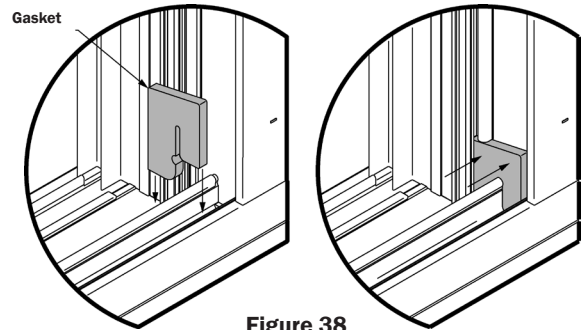


Figure 38

### ATTACH SILL STOP

39. Before attaching sill stop to sill, apply a 1/4" bead of silicone along the full length of stop (Fig. 39).

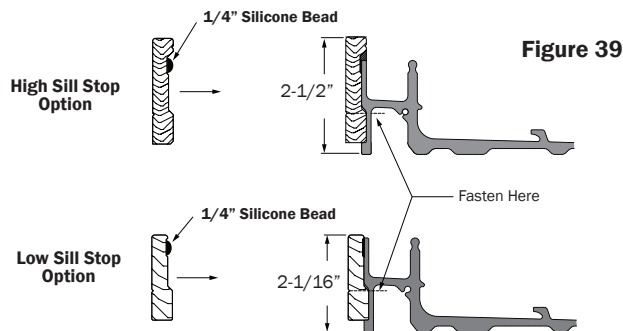


Figure 39

40. Attach sill stop to sill using 1-1/4" Braid Nails, placed 8-10" apart, through the locator line on the stop (Fig. 39 & 40).

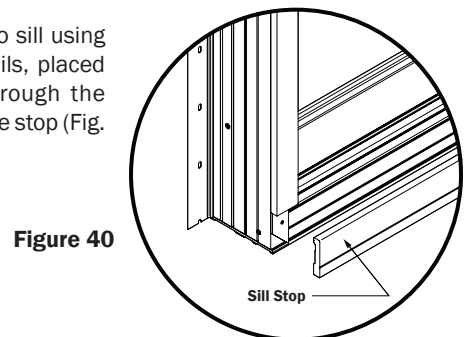
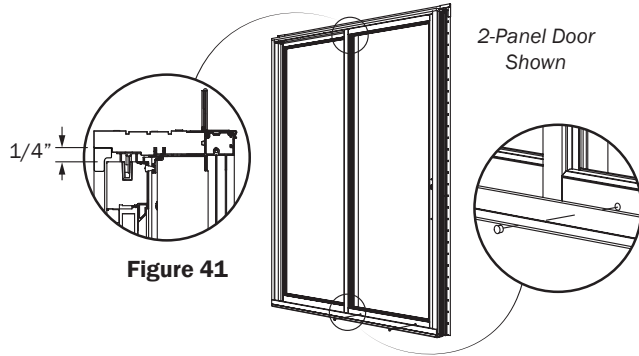


Figure 40

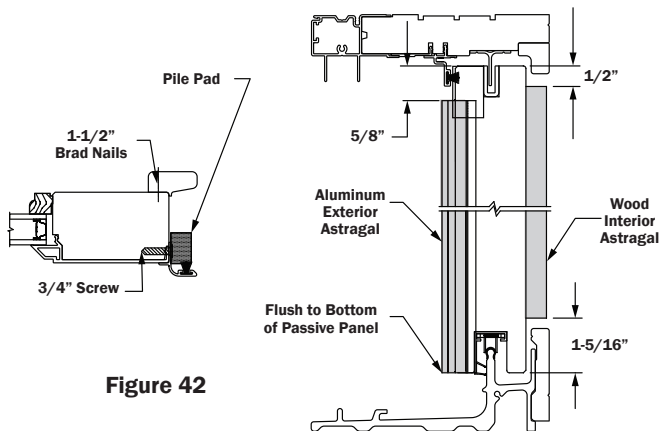
## PANEL ADJUSTMENT

40. To adjust the panels, the rollers can be accessed using the holes on the face of the bottom rails. Each roller can be adjusted separately using a phillips head screwdriver. Turning clockwise raises the panel and counter clockwise lowers the panel. Adjust until panel glides smoothly on the track and panel is plumb and level with the head. Top of panel should be approximately 1/4" from the head (Fig. 41).



41. Install the provided plastic roller adjustment hole plugs when adjustment is complete.

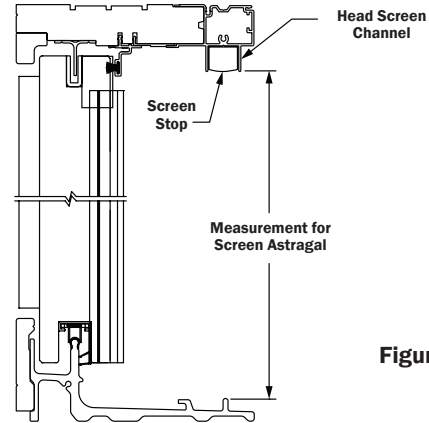
## ASTRAGAL APPLICATION - OXXO ONLY



42. Glue wood interior astragal onto interior of passive panel 1/2" from top of panel and 1-5/16" from bottom of passive panel.
43. Attach wood interior astragal to passive panel using 18ga x 1-1/4" brad nails 8" to 10" apart.
44. Apply a bead of caulk to the back of the aluminum astragal along it's entire length and place astragal onto exterior of passive panel 5/8" from top of panel and flush to bottom of panel.
45. Attach aluminum exterior astragal to passive panel using the supplied #8 x 3/4" flat head screws 12" O.C. max.
46. Attach the 1/2" x 3/4" x 1-1/4" pile pad to top of passive panel.

## SCREEN APPLICATION

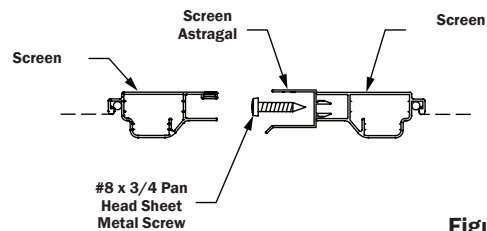
47. Install the screens per the instructions included in the screen packet.
48. Measure the distance between the head screen channel and the screen roller track. Cut the screen astragal 1/8" shorter than this measurement (Fig. 43).



49. Holding the astragal in place on the edge of the screen, drill an 1/8" hole into the interior screen wall. After drilling the first hole, screw the astragal to the screen using a #8 x 3/4" pan head screw to hold it in place while drilling the rest of the holes (Fig. 44).

Finish installing the remaining screws.

50. Attach screen stop in the head screen channel at the center of the door using the provided #8 x 3/4" pan head sheet metal screw (Fig. 44).
51. Install screen door strike per manufacturer's instructions included in the screen packet.



**This concludes the assembly for a  
Lincoln Slide Patio Door.**